

HIMMEL™
INTERIOR SYSTEMS

PRODUCT GUIDE

DESIGNING SPACES
THAT INSPIRE

1300 374 253 | www.himmel.com.au

CSR



ABOUT HIMMEL

CSR HIMMEL is an integral member of CSR's building products group and committed to leading the way by delivering productive and intelligent spaces through performance and design led solutions. Our diverse international portfolio of brands ensures a record of exceptional design and high performance in all of our products – in every setting. With our insights and technical leadership, we help our customers design spaces that inspire the people within them.



CONTENTS

CONTENTS

Gyprock Plasterboard Ceiling Tiles	5
OWA Mineral Fibre Ceiling Tiles	8
Ecophon Ceiling Tiles	13
Troldtekt Woodwool Ceiling Tiles and Wall Panels	16
Martini Decorative and High Performance Acoustics	22
Rondo Steel Grid Systems	42
Fricker Aluminium Grid Systems	50
Himmel Aluminium Partitions and Skirting	55

OUR GLOBAL PRODUCT PARTNERS



Ecophon, a part of global Saint-Gobain building products group, manufacture high acoustic glasswool ceiling tiles and wall panels in Sweden. Passionate about acoustics, Ecophon products assist in enhancing the wellbeing and performance of individuals in the spaces that they work and live.



The Fricker Ceiling Systems range has been a long-standing brand in the Australian CBD market, with the ability to custom build solutions for even the toughest designs.



Gyprock is Australia's leading plasterboard manufacturer since 1947. They produce a wide range of gypsum based products such as plasterboard and cornice, as well as compounds, adhesives, specialty plasters and associated finishing materials and accessories. Gyprock plasterboard is used to manufacture our wide range of plasterboard ceiling tiles.



Himmel Interior Systems series of aluminium partitioning systems incorporates a number of design elements that are largely interchangeable. Himmel Aluminium partitioning suite includes Partitions, Skirting and Flat Bar, Doors & Sliders and Hardware & Accessories



Proudly Australian-owned and manufactured with over 27 years of experience, CSR Martini's acoustic products have been specially engineered to perform across multiple environments. Offering non-exposed insulation, semi exposed absorptive products, and decorative acoustic solutions to be used alone or in combination.



OWA have been developing, producing and marketing suspended ceiling tiles made from mineral wool, steel grid and accessories for over 50 years.



Rondo have been at the forefront of innovation, service and product quality for over 50 years. It's Rondo's reputation for producing market-leading wall and ceiling systems, as well as offering expert technical design and sales support that has led to Rondo being a part of the best projects worldwide.



Troldekt manufacture acoustic ceiling and wall panels from natural materials. The products are designed and developed in Denmark from local materials using state of the art and eco-friendly technology.

GYPROCK®

CSR Gyprock is Australia's leading manufacturer of gypsum based products such as plasterboard and cornice, as well as compounds, adhesives, specialty plasters and associated finishing materials and accessories.

Gyprock supplies a comprehensive range of high performance products and systems for many applications to meet fire, acoustic and thermal requirements across all segments of the construction industry.

To compliment a strong retail presence in major hardware and building material retail outlets, Gyprock also operates Gyprock Trade™ centres. These trade-focused outlets supply everything the plastering trade needs from boards and cornices to compounds, tapes, tools and accessories.

The vast majority of Gyprock products are manufactured in company owned, state-of-the-art manufacturing facilities across Australia. Each facility conducts regular testing under a Quality Management System complying with ISO 9001/2000 to ensure you can specify and use our products with utmost confidence.



[CLICK HERE TO LEARN MORE](#)



Freshtone™ Diamond White Vinyl Face

Gyprock Freshtone™ is a plasterboard panel finished with a finely textured vinyl laminate.

ORDER CODE	EDGE	SIZE	M ² /each	Each/carton
10115	3	1200 x 600 x 10mm	0.72	1

SQ = 3 SLT = 6 SBK = 1/3

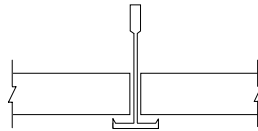

SQUARE EDGE (SQ)

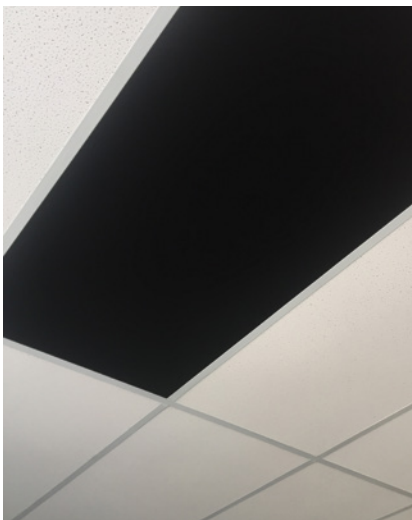

Freshtone Black Vinyl Face

Gyprock Freshtone™ Black is a plasterboard panel finished with a finely textured black vinyl laminate.

ORDER CODE	EDGE	SIZE	M ² /each	Each/carton
114740	3	1200 x 600 x 10mm	0.72	1

SQ = 3 SLT = 6 SBK = 1/3

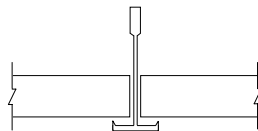

SQUARE EDGE (SQ)



Supatone™ Bright White Paper Face

Gyprock Supatone Bright is a plasterboard panel with a 'wipe clean' smooth polycoated surface paper laminate.

ORDER CODE	EDGE	SIZE	M ² /each	Each/carton
474998	3	1200 x 600 x 10mm	0.72	1

SQ = 3 SLT = 6 SBK = 1/3

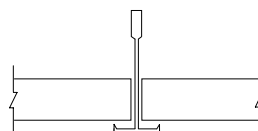

SQUARE EDGE (SQ)



Perforated Panel Vinyl Face

Gyprock® Perforated Panels have been specifically developed for use in ceilings where additional sound absorption is required.

ORDER CODE	EDGE	SIZE	M ² /each	Each/carton
10127	3	1200 x 600 x 13mm	0.72	1

SQ = 3 SLT = 6 SBK = 1/3

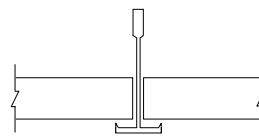

SQUARE EDGE (SQ)



Arctic White Vinyl Face (WA ONLY)

Gyprock Arctic White Vinyl Face is a plasterboard panel finished with a finely textured vinyl laminate.

ORDER CODE	EDGE	SIZE	M ² /each	Each/carton
103423#	3	1200 x 600 x 10mm	0.72	1

#Available in WA Only

SQ = 3 SLT = 6 SBK = 1/3

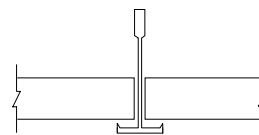

SQUARE EDGE (SQ)



Driven by entrepreneurial courage and determination, we continuously develop our processes and products.

OWA stands for innovative and sustainable ceiling systems for almost every industry including education, commercial, sports & leisure, retail, hospitality and healthcare. With mineral ceiling systems based on premium Odenwald mineral wool, OWA is focused on delivering high quality, high-performance products that last.

Sustainability OWA mineral ceilings are made in Germany from a high-quality mix of natural and recycled materials, approx. 80% of our raw ingredients originate locally. We produce our own bio-soluble mineral wool, ensuring complete control over the production process.

Awarded the German RAL quality mark for products made of mineral wool, OWA ceilings are produced to ISO 14001 for Environmental Management, use solvent-free dispersion paints, and feature up to 54% recycled content.

Achieving GreenTag GreenRate Level A, our mineral ceilings potentially contribute to Green Star points including acoustic comfort, lighting comfort, sustainable products, life cycle impacts and more.

[CLICK HERE TO LEARN MORE](#)





NRC
0.70

CAC
35

RH
99



Constellation A

Mineral Fibre ceiling tile that offers good acoustic properties with a traditional face pattern.

ORDER CODE	EDGE	SIZE	M ² /each	Each/carton
162187	3	1200 x 600 x 14mm	0.72	10

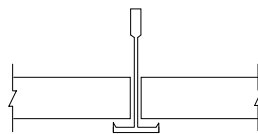

SQUARE EDGE (SQ)

SQ = 3 SLT = 6 SBK = 1/3

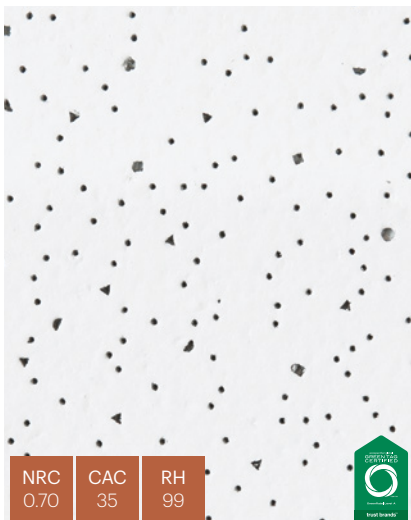

NRC
0.70

CAC
35

RH
99



Finetta

Mineral Fibre Ceiling Tile offering good acoustic properties with a fine fissured face pattern.

ORDER CODE	EDGE	SIZE	M ² /each	Each/carton
162184	3	1200 x 600 x 15mm	0.72	10
167899*	3	600 x 600 x 15mm	0.36	12
162186	6	1200 x 600 x 15mm	0.72	10

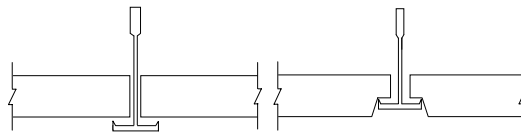

SQUARE EDGE (SQ)

SHADOWLINE TEGULAR (SLT)

SQ = 3 SLT = 6 SBK = 1/3



NRC
0.65

CAC
37

RH
99



Sandila New

Mineral fibre ceiling tile that offers good acoustic properties with a durable face pattern.

ORDER CODE	EDGE	SIZE	M ² /each	Each/carton
162115	3	1200 x 600 x 15mm	0.72	10
162116*	6	1200 x 600 x 15mm	0.72	10

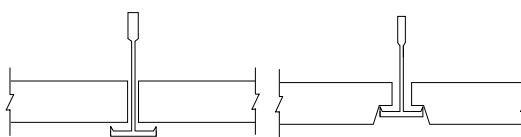

SQUARE EDGE (SQ)

SHADOWLINE TEGULAR (SLT)

SQ = 3 SLT = 6 SBK = 1/3

* This item is made to order, therefore minimum order quantities and/or lead times may apply. Please contact the Himmel team for further information.

MINERAL FIBRE CEILING TILES

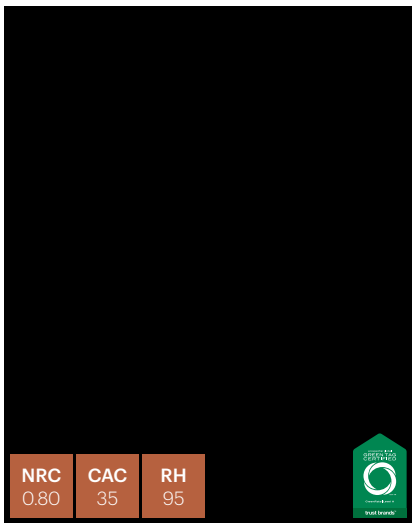

Sinfonia Black 15mm

Mineral fibre ceiling tile that offers premium acoustic properties and a modern, black clean face pattern.

ORDER CODE	EDGE	SIZE	M ² /each	Each/carton
162119	3	1200 x 600 x 15mm	0.72	10

SQ = 3 SLT = 6 SBK = 1/3

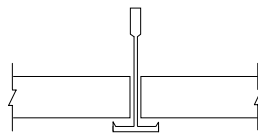

SQUARE EDGE (SQ)

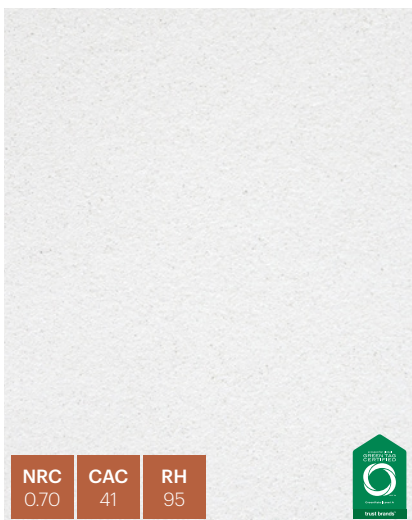

Sinfonia Privacy

Mineral fibre ceiling tile that offers premium acoustic properties and a modern, clean face pattern.

ORDER CODE	EDGE	SIZE	M ² /each	Each/carton
164980	3	1200 x 600 x 20mm	0.72	8
451417	3	600 x 600 x 20mm	0.72	8

SQ = 3 SLT = 6 SBK = 1/3

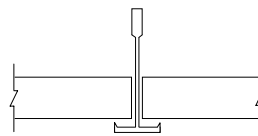

SQUARE EDGE (SQ)

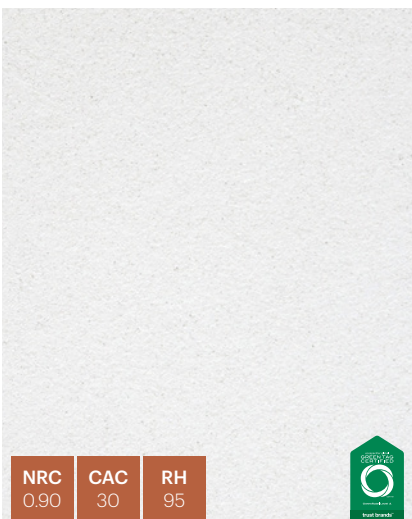

Brillianto A 15mm

Mineral fibre ceiling tile with premium acoustic properties and a modern smooth monolithic face pattern.

ORDER CODE	EDGE	SIZE	M ² /each	Each/carton
160094	3	1200 x 600 x 15mm	0.72	10
160095*	3	600 x 600 x 15mm	0.36	12

SQ = 3 SLT = 6 SBK = 1/3

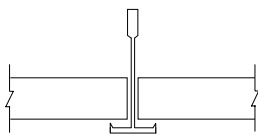

SQUARE EDGE (SQ)

* This item is made to order, therefore minimum order quantities and/or lead times may apply. Please contact the Himmel team for further information.

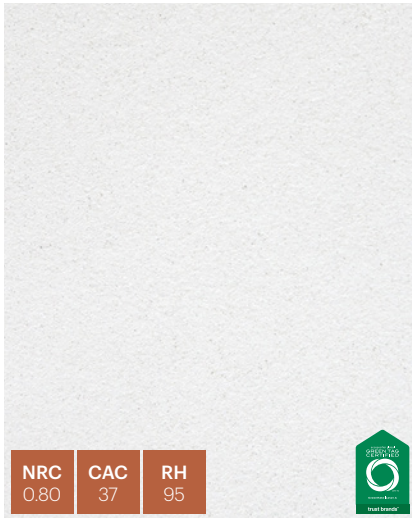

Sinfonia Balance

Mineral fibre ceiling tile that offers premium acoustic properties and a modern, clean face pattern.

ORDER CODE	EDGE	SIZE	M ² /each	Each/carton
196969	3	1200 x 600 x 20mm	0.72	8
196970*	3	600 x 600 x 20mm	0.36	10
197062*	6	600 x 600 x 20mm	0.36	10

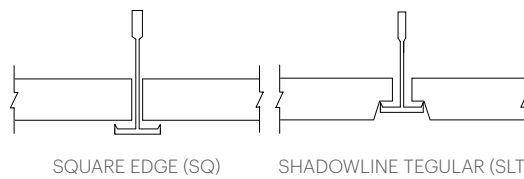

SQ = 3 SLT = 6 SBK = 1/3

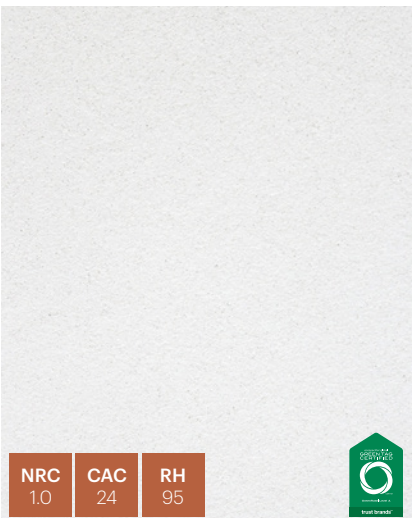

Sinfonia Silencia

ORDER CODE	EDGE	SIZE	M ² /each	Each/carton
197825*	3	1200 x 600 x 20mm	0.72	8
197827*	6	1200 x 600 x 20mm	0.72	8

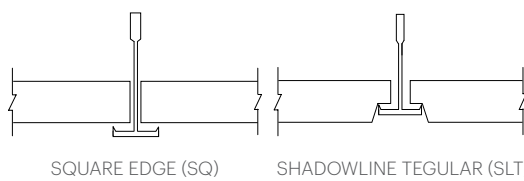

SQ = 3 SLT = 6 SBK = 1/3

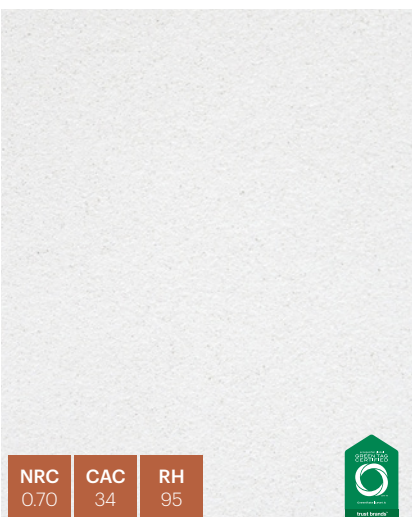

Sinfonia C

Mineral fibre high performance ceiling tile that offers premium acoustic properties and a modern, clean face pattern.

ORDER CODE	EDGE	SIZE	M ² /each	Each/carton
116791	1/3	1187 x 397 x 15mm	0.47	10
121589	1/3	1337 x 446.5 x 15mm	0.60	10

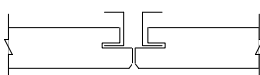

SQ = 3 SLT = 6 SBK = 1/3

KERFED, BEVELLED AND CUT BACK (SBK)

* This item is made to order, therefore minimum order quantities and/or lead times may apply. Please contact the Himmel team for further information.

MINERAL FIBRE CEILING TILES

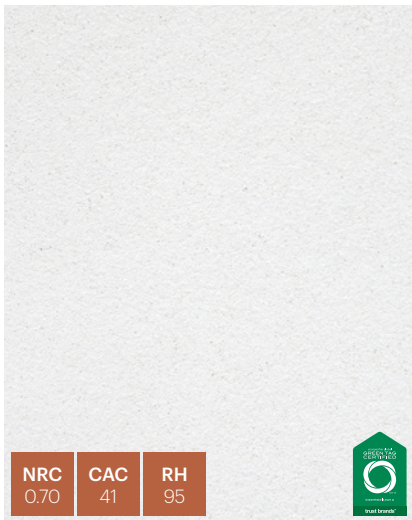

Sinfonia Privacy Humancare

Mineral fibre ceiling tile that offers premium acoustic properties and a modern, clean face pattern.

ORDER CODE	EDGE	SIZE	M ² /each	Each/carton
451804	3	1200 x 600 x 20mm	0.72	8

SQ = 3 SLT = 6 SBK = 1/3

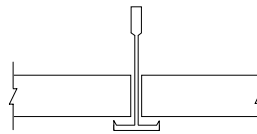

SQUARE EDGE (SQ)

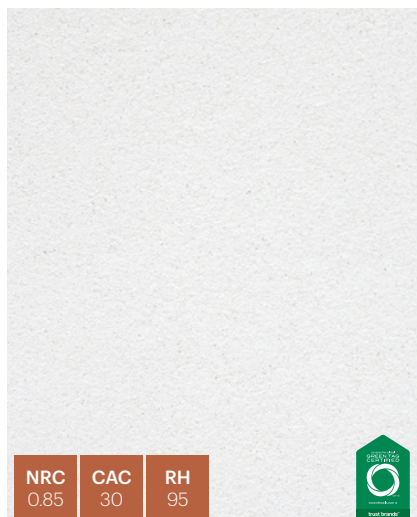

Sinfonia Humancare 15mm

Mineral Fibre ceiling tile that offers premium acoustic properties and prevents the spread of bacteria, fungi, and germs.

ORDER CODE	EDGE	SIZE	M ² /each	Each/carton
162120	3	1200 x 600 x 15mm	0.72	10
114745	3	600 x 600 x 15mm	0.72	10

SQ = 3 SLT = 6 SBK = 1/3

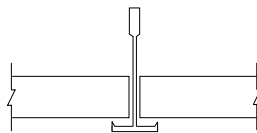

SQUARE EDGE (SQ)

Saint-Gobain Ecophon develops, manufactures, and markets acoustic products and systems that contribute to a good working environment by enhancing peoples' wellbeing and performance. Ecophon's promise 'A sound effect on people' is the core backbone of everything they do. Ecophon has an embedded passion and conviction that room acoustics are an integral component of any great work environment, that benefits people and the environment. Ecophon knows, every student deserves to hear and understand their teacher, every patient should be spared from a stressful sound environment, every office worker should be able to concentrate on their task and communicate with their colleague and no factory worker should have to risk their safety due to a noisy work environment.

Sustainability

Ecophon is building on better principles, materials, and transparency to bring credible sustainability back to our industry. Ecophon believe that true sustainability has nothing to hide. That working to its highest ideals is a natural part of having a sound effect on people. And that if they want sustainability to be meaningful, it must start with an honest approach, high ambition, and the best of intentions.

[CLICK HERE TO LEARN MORE](#)



GLASSWOOL CEILING TILES AND WALL PANELS



NRC
0.70

RH
95

Ecophon™ Sombra

Ecophon Sombra A is a black glasswool ceiling tile that provides high sound absorption properties. It is ideal for commercial applications such as movie theatres or lecture theatres.

ORDER CODE	EDGE	SIZE	M ² /each	Each/carton
194743	SQ	1200 x 600 x 15mm	0.72	14

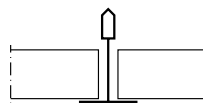

EDGE A

A = SQ Ds = Concealed E = Angled Tegular F=Tongue and Groove



NRC
0.85

CAC
21

RH
95

Ecophon™ Focus

Ecophon Focus A is a glasswool ceiling tile that can be used in a variety of applications. It is most suitable for office and educational ceilings due to its high acoustic properties and modern face pattern. It has an exposed grid system and the edges are primed. applications such as movie theatres or lecture theatres.

ORDER CODE	EDGE	SIZE	M ² /each	Each/carton
91224	SQ	1200 x 600 x 20mm	0.72	14
91223*	SQ	600 x 600 x 20mm	0.36	28
86405	Concealed	1200 x 600 x 20mm	0.72	10
86404	Concealed	600 x 600 x 20mm	0.36	20
91228	Angled Tegular	1200 x 600 x 20mm	0.72	10
91227*	Angled Tegular	600 x 600 x 20mm	0.36	20
91583	Shiplap	1200 x 600 x 20mm	0.72	10
91229	Shiplap	600 x 600 x 20mm	0.36	20

Colour: White Frost. Other colours: MTO, MOQ & lead time apply

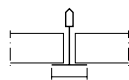

EDGE A

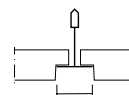

EDGE E

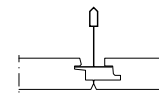

EDGE Ds



EDGE F

A = SQ Ds = Concealed E = Angled Tegular F=Tongue and Groove



NRC
0.80

RH
95

Ecophon™ Advantage A

Ecophon Advantage A Panels are a high acoustic glasswool ceiling tile that achieves essential demands of a commercial ceiling. Each tile is individually demountable and is available with either natural or primed edges.

ORDER CODE	EDGE	SIZE	M ² /each	Each/carton
127734	SQ	1200 x 600 x 15mm	0.72	20

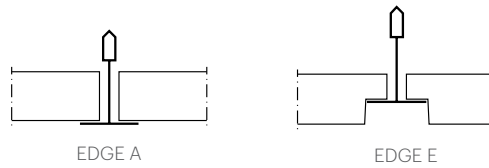

A = SQ Ds = Concealed E = Angled Tegular F = Tongue and Groove



NRC
1.00

RH
95

CAC
30

Ecophon™ Master

Ecophon Master A is a glasswool ceiling tile which is suitable for open plan spaces where good acoustics are imperative to the design.

ORDER CODE	EDGE	SIZE	M ² /each	Each/carton
96563	SQ	1200 x 600 x 40mm	0.72	10
93802*	SQ	600 x 600 x 40mm	0.36	20
100761	Shiplap	600 x 600 x 40mm	0.36	10

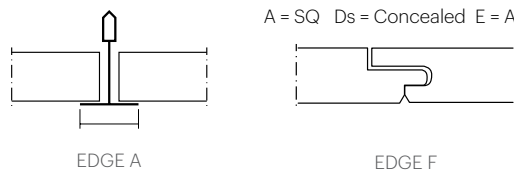

A = SQ Ds = Concealed E = Angled Tegular F = Tongue and Groove



NRC
0.80

RH
95

Ecophon™ Hygiene

Ecophon Hygiene Advance A is a glasswool ceiling tile that is suitable for use in Healthcare applications. This tile is fully encapsulated in a smooth high performance film that is impervious to particles and water.

ORDER CODE	EDGE	SIZE	M ² /each	Each/carton
107082*	SQ	1200 x 600 x 15mm	0.72	20
10321	SQ	1200 x 600 x 20mm	0.72	14
36714*	SQ	1200 x 600 x 20mm	0.72	14

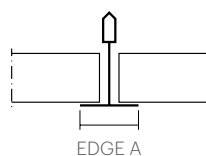

A = SQ Ds = Concealed E = Angled Tegular F = Tongue and Groove

* This item is made to order, therefore minimum order quantities and/or lead times may apply. Please contact the Himmel team for further information.

Since 1935, Troldtekt acoustic panels have been manufactured from the natural material wood, and cement extracted from Danish mineral resources. Troldtekt design, develop and manufacture the panels in Denmark – from local materials and under state-of-the-art and eco-friendly conditions. Today, Troldtekt acoustic panels are among the leading and preferred solutions for ensuring high quality sound environments. Troldtekt panels can clad ceilings and walls in offices, commercial and industrial buildings and in public facilities such as schools, kindergartens, cultural centres, sports centres, swimming pools as well as private residences.

Troldtekt makes a real audible difference, including in minimalist architecture where good acoustics are often challenged by the extensive use of hard surfaces.

Good acoustics with a focus on sustainability. With an intense focus on making a positive contribution to the environment, Troldtekt bases its business strategy on the internationally recognised Cradle to Cradle principles of the circular economy. This means it is fully focused on sustainability throughout the lifecycle of its products, from the extraction of raw materials and production, to the use and re-use of its used acoustic panels.

[CLICK HERE TO LEARN MORE](#)

Troldekt Structures



Extreme Fine



Ultrafine



Fine



Coarse



Natural wood

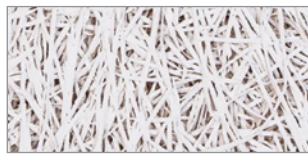

White 101

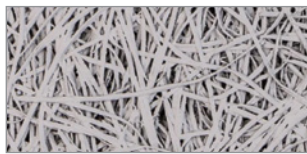

Grey 202

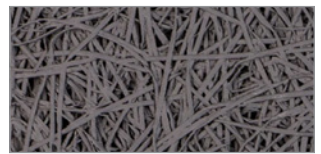

Grey 208



Black 207

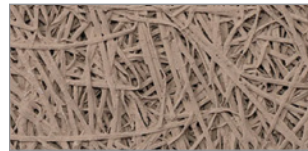

Clay 210 (FUTURECEM)

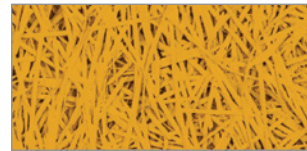

Custom colour

Troldekt Edge Details

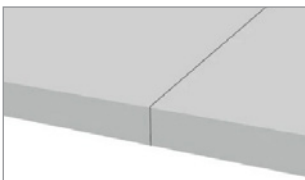

K0

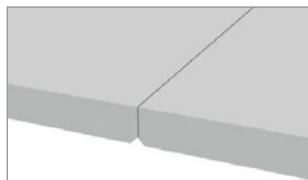

K5

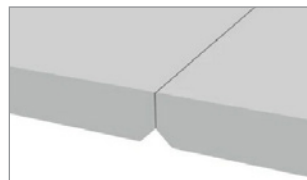

K11

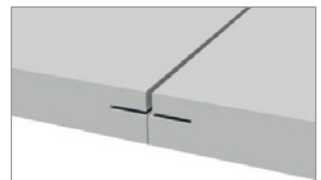

K0-N

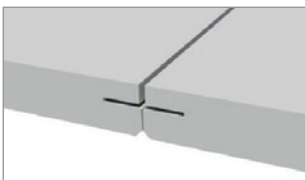

K5-N

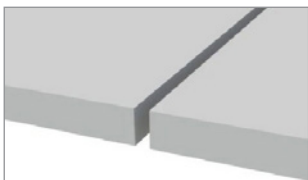

K0-S

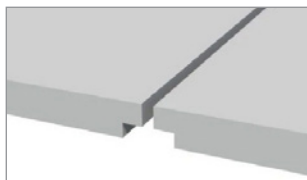

K0-FS

Extreme Fine

ORDER CODE	EDGE	SIZE	COLOUR	M ² /each	Installation
164306	K5	1200 x 600 x 25mm	Natural	0.72	Direct Fix

Ultra Fine

ORDER CODE	EDGE	SIZE	COLOUR	M ² /each	Installation
170041	K0-S	1193 x 593 x 25mm	Black 207 FutureCem	0.72	Exposed Grid System
455524	K0-S	1193 x 593 x 25mm	Natural	0.72	Exposed Grid System
164302	K0	1200 x 600 x 25mm	Natural	0.72	Direct Fix
164303	K5	1200 x 600 x 25mm	Natural	0.72	Direct Fix
164305	K5	1200 x 600 x 25mm	Black 207 FutureCem	0.72	Direct Fix
164304	K5	1200 x 600 x 25mm	White 101	0.72	Direct Fix
193291	K5-N	1200 x 600 x 35mm	Natural	0.72	Furring Channel
164511*	K11	1200 x 600 x 25mm	Natural	0.72	Direct Fix

Coarse

ORDER CODE	EDGE	SIZE	COLOUR	M ² /each	Installation
481860*	K5	1200 x 600 x 25mm	Natural	0.72	Direct Fix



TROLDTEKT DESIGN SOLUTIONS

Troldtekt Design Solution allow you to combine aesthetics with acoustics properties. You can create your own patterns and rhythms in the design – and vary and scale the given design. This gives you great freedom to harmonise form and function in all types of buildings.

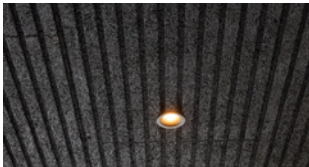

Troldtekt® line



Troldtekt® line design



Troldtekt® tilt line



Troldtekt® dots



Troldtekt® curves

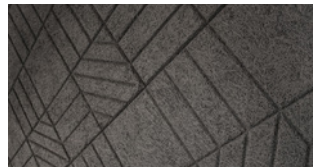

Troldtekt® puzzle



Troldtekt® tiles



Troldtekt® rhombe

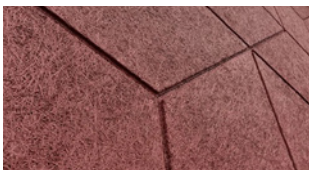

Troldtekt® rhombe mini

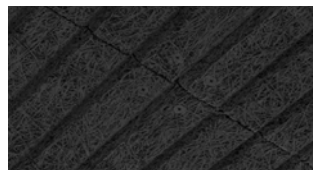

Troldtekt® v-line 1way

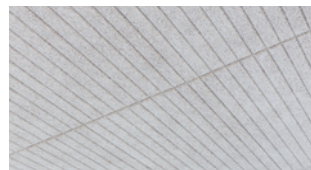

Troldtekt® v-line 2way

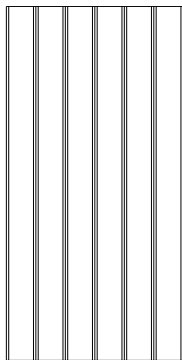

TROLDTEKT V-LINE
1WAY 6

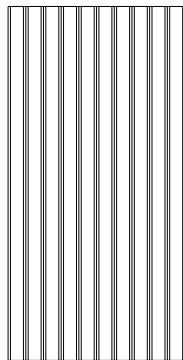

TROLDTEKT V-LINE
1WAY 10

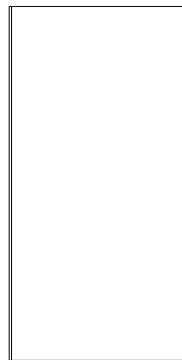

TROLDTEKT
V-LINE 1WAY BLANK

TROLDTEKT LINE

Troldtekt line provides an elegant, uniform ceiling surface with no visible joints, with the characteristic look of a timber batten ceiling.

ORDER CODE	EDGE	SIZE	COLOUR	M ² /each	Installation
458140	KO	1200 x 600 x 35mm	Natural*	0.72	Direct Fixed
	KO	1200 x 600 x 35mm	White 101*	0.72	Direct Fixed
	KO	1200 x 600 x 35mm	Grey 202*	0.72	Direct Fixed
TBA	KO	1200 x 600 x 35mm	Grey 208 Futurecem*	0.72	Direct Fixed
TBA	KO	1200 x 600 x 35mm	Natural Grey Futurecem*	0.72	Direct Fixed
458141	KO	1200 x 600 x 35mm	Black 207 Futurecem*	0.72	Direct Fixed

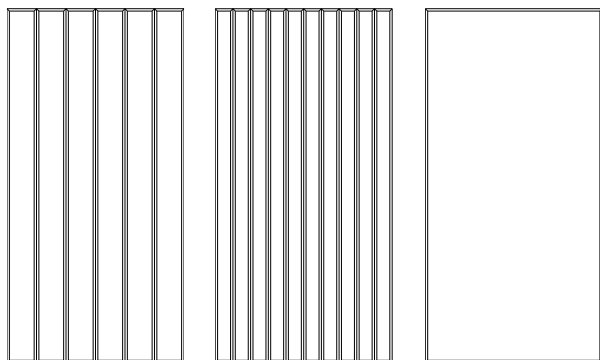

TROLDTEKT
V-LINE 2WAY 6

TROLDTEKT V-LINE
2WAY 10

TROLDTEKT V-LINE
2WAY BLANK

TROLDTEKT V- LINE 1 WAY/2 WAY

Troldtekt v-line - acoustic panels with v-shaped grooves for an elegant and uniform ceiling. Available in six or ten v-shaped longitudinal grooves.

ORDER CODE	EDGE	SIZE	COLOUR	M ² /each	Installation
481279	KO	1200 x 600 x 25mm	Natural*	0.72	Direct Fixed
481281	KO	1200 x 600 x 25mm	Black 207 Futurecem*	0.72	Direct Fixed
TBA	KO	1200 x 600 x 25mm	White 101*	0.72	Direct Fixed
TBA	KO	1200 x 600 x 25mm	Grey 202*	0.72	Direct Fixed
TBA	KO	1200 x 600 x 25mm	Grey 208 Futurecem*	0.72	Direct Fixed
TBA	KO	1200 x 600 x 25mm	Natural Grey Futurecem*	0.72	Direct Fixed

Troldtekt Accessories

ORDER CODE	PRODUCT	SIZE	Each/carton
164308	White 101 Screws	4.2 x 45mm	100
164309	Black 207 Screws	4.2 x 45mm	100
164310	Natural Screws	4.2 x 45mm	100
164311*	White 101 Screws	4.2 x 50mm	100
164312*	Black 207 Screws	4.2 x 55mm	100
162912	Natural Screws	4.2 x 55mm	100
470624	Black 207 Touch Up Paint	750ml	-
470621	White 101 Touch Up Paint	750ml	-
470622	Grey 202 Touch Up Paint	750ml	-
470623	Grey 208 Touch Up Paint	750ml	-



Troldtekt Screw



Screw Face



* This item is made to order, therefore minimum order quantities and/or lead times may apply. Please contact the Himmel team for further information.



Proudly Australian owned and manufactured with over 27 years of experience, our acoustic products have been specially engineered to perform across multiple environments. Offering non-exposed insulation, semi exposed absorptive products, and decorative acoustic solutions to be used alone or in combination, CSR Martini are the experts at integrating design and performance so that the desired outcome is reached both functionally and aesthetically.

You can genuinely feel, see, and hear the difference with CSR Martini products. Everything created is a balance between science and design. Products are engineered to help minimise and reduce sound reverberation where it matters most.

[CLICK HERE TO LEARN MORE](#)

About CSR Martini

At CSR Martini, we know the difference between sound and noise.

Proudly Australian manufactured with over 27 years of experience behind us, our acoustic products have been specifically engineered to perform across multiple environments - and even within different interior spaces.

Offering non-exposed insulation, semi-exposed absorptive products and decorative acoustic solutions to be used alone or in combination, we are the experts at integrating design and performance so that your desired outcome is reached both functionally and aesthetically.

From prominent Australian landmarks to industrial overhauls, whether it be for a commercial, hospitality or cultural space, recording studio, schools, theatres or convention centres, we sustainably engineer solutions for the most challenging acoustic layouts to ensure auditory excellence.

Why acoustics matter

We believe that sound can impact our environment for better or worse.

Studies show that poor acoustics can reduce student learning, productivity in workplaces, affect hospital recovery periods, as well as detract from our experience in social settings. The effects are wide and far reaching.

Couple this with increased trends towards more collaborative, open-plan spaces, actively managing noise levels is paramount to ensure you get the most out of your surroundings.

At CSR Martini, we engineer environments that transform the collective experience of those within them, reducing the impact of noise where it's not wanted.

Experience the difference with our range.



Environment

At CSR Martini, we believe we all have a role to play in looking after the environment. No doubt you feel the same.

To us, it's not just about creating exceptional quality products.

We ensure our manufacturing impact, our footprint and every single touch point from production to final delivery is considered.

Why? Because as a responsible corporate citizen, we are committed to leaving our next generation and the world better than we found it.

But actions speak louder than words. We are proud to say we are leading the way by ensuring our products, along with our manufacturing process, have been certified to independent environmental and product health assessments.

- Products with recycled content reduce greenhouse gas emissions
- High reusable potential
- Products manufactured from thermally bonded polyester fibre have a minimum of 60% recycled fibre content from PET packaging such as empty drink bottles
- The products are 100% recyclable
- No ozone-depleting gases are used during the manufacturing process
- No red list chemicals are present
- Safe, non-irritant, non-toxic, and non-allergenic

CSR Martini products are proudly:

- GreenTag^{Cert}™ certified
- Environmental Product Declaration (EPD) certified in accordance with ISO 14025
- Product Health Declaration (PHD) certified
- Declare certified
- Suitable for Green Star™ projects



dECO Finishes

CSR Martini's dECO fabric range is available in either a Flat Felt or Velour finish.

The dECO colour range offers freshness and vitality to any interior space. Colours have been inspired by the beauty of our world. From the calming palette of neutrals to the vibrant pops of life, dECO Felt and dECO Velour will elevate your design whilst delivering acoustic performance.

The impact colours have on individuals is extraordinary. It can sway thinking, change actions, and cause reactions. It can irritate or soothe your eyes, raise your blood pressure or suppress your appetite.

At CSR Martini we know when colours are used in the right way they can add so much more to the space. Have design freedom with our extensive range of fabric colours and finishes.



Felt Flat Acoustic Fabric

Application	Bonded to fabricated Martini products: dECO Blades, dECO Clouds, dECO Screens, dECO 3D Tiles, dECO Stick It and dECO Ceiling Tiles
Thickness	1-2mm
Width	1350mm
Fire resistance	Complies with AS 5637.1 and is tested to AS/ ISO 9705 and achieves Group 1 SMOGRA less than 100 m ² /s ² x 1000
Acoustic performance	Tested to AS/ISO 354 and achieves NRC 0.04 direct fix



Velcro® Receptive Acoustic Fabric

Application	Velcro® receptive fabric bonded to fabricated Martini products: dECO Quiet Panel and dECO Flex
Thickness	3-4mm
Width	1350mm
Fire resistance	Complies with AS 5637.1 and is tested to AS/ ISO 9705 and achieves Group 1 SMOGRA less than 100 m ² /s ² x 1000
Acoustic performance	Tested to AS/ISO 354 and achieves NRC 0.04 direct fix

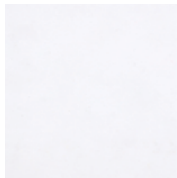

Snow

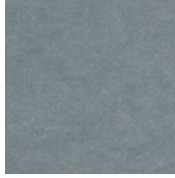

Neptune



Moss



Bolt

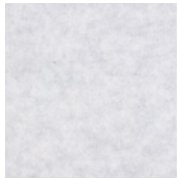

Lace



Nordic Sky

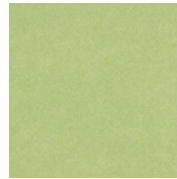

Apple



Bumble Bee

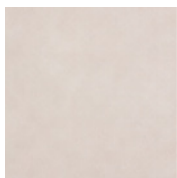

Porcelain



Summit



Citrus



Tiger

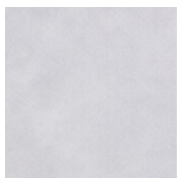

Ice

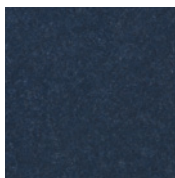

Sapphire



Shamrock



Cherry

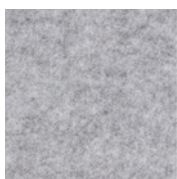

Granite

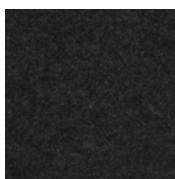

Ash

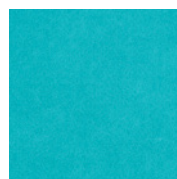

Ariel

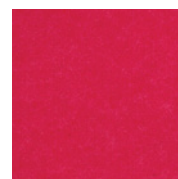

Candy

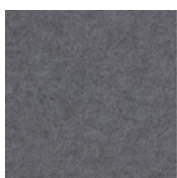

Platinum



Pitch

dECO Product Selection Guide

	Application		Available Finishes			Installation Options				
	Wall	Ceiling	dECO Felt	dECO Velour	Board	Direct Fix	Soffit Suspension	Ceiling Grid Suspension	Plasterboard Suspension	Exposed Ceiling Grid System
dECO Quiet Panel				
dECO Flex	.			.		.				
dECO Clouds		
dECO Blades		
dECO Screens		
dECO Ceiling Tiles		.	.							.
dECO 3D Tiles	.		.			.				
dECO Stick It	.		.			.				
dECO Deluxe				
dECO Quiet Board				



High Performing Fabric Faced Acoustic Panel

Intended use	Interior wall, ceiling panelling and pin boards
Thickness	9mm, 15mm, 25mm, 50mm Tolerance: +/- 2mm
Panel size	2420mm x 1210mm, 2720mm x 1210mm Tolerance: length +/- 10mm width +/- 5mm
Fire resistance	Complies with AS 56371 and is tested to AS/ ISO 9705 and achieves Group 1 SMOGRA less than 100 m ² /s ² x 1000
Acoustic performance	Tested to AS/ISO 354 and achieves: 9mm NRC 0.30 direct fix 15mm NRC 0.50 direct fix 25mm NRC 0.85 direct fix 50mm NRC 1.00 direct fix
Warranty	15 year product warranty
Framing System	dECO Edge to suit 15mm, 25mm and 50mm dECO Quiet Panel available in Clear Anodised Silver, Matt Black and Flat White finish.
Finish	



Velcro® Receptive, Flexible Acoustic Wall Covering

Intended use	Interior wall, ceiling panelling and pin boards
Thickness	10-12mm
Width	1220mm Tolerance: +/- 5mm
Roll Length	25m Other lengths available upon request. Minimum length 7m. There may be a 10% over or under supply.
Fire resistance	Complies with AS 56371 and is tested to AS/ ISO 9705 and achieves Group 1 SMOGRA less than 100 m ² /s ² x 1000
Acoustic performance	Tested to AS/ISO 354 and achieves: NRC 0.40 direct fix
Warranty	15 year product warranty
Finish	

Acoustic Blades with Verto™ Hanging System

Intended use Interior decorative acoustic blades for ceilings and walls

Designs dECO Blades Linear, dECO Blades Wedge, dECO Blades Arrow, dECO Blades Movement

Blade thickness 27mm
Tolerance: +/- 2mm

Blade widths Available in 2400mm, 1800mm and 1200mm
Tolerance +/- 2mm

Fire resistance Complies with AS 5637.1 and is tested to AS/ ISO 9705 and achieves Group 1 SMOGRA less than 100 m²/s² x 1000

Acoustic performance Tested to AS/ISO 354 and achieves NRC 0.90
Based on dECO Blade Linear 2400mm x 200mm x 27mm in 6m² module with 103mm spacing.

Warranty 15 year product warranty

Finish  **martini**
dECO FELT

Installation dECO Blades is installed on the Verto™ system that can be direct fixed, suspended from soffit or ceiling grid, or directly integrated with the Rondo KEY-LOCK® System.

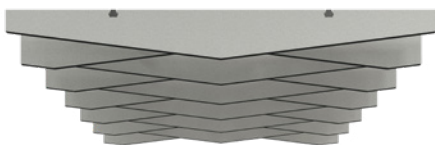

Movement



Arrow



Wedge



Linear



VERTO™

Inspired by the word 'vertebrae', Verto™ is a unique innovative hanging and mountable system that can be fixed on the ceiling or the wall to provide a myriad of different applications and suspension methods.

As functional as it is versatile, Verto™ is a patented technology that provides the backbone to our dECO Blades and dECO Screens to bring your design vision to life, while offering all the signature acoustic enhancing benefits you can expect from any CSR Martini product.



For more details, including system performance and structural certifications, scan the QR code or visit csmartini.com.au

Verto™ System Overview

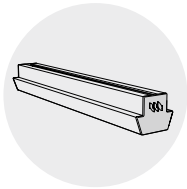

Verto™ Extrusion

Engineered aluminium modular mounting system designed for dECO Blades and dECO Screens.

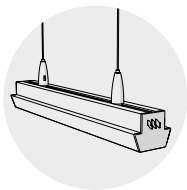

Hardware

The hardware options available give you the flexibility to fix on a ceiling or a wall providing a range of different executions and interior suspension effects.

- Suspended Grid
- Suspended Soffit
- Direct Fix
- Rondo KEY-LOCK® Integration
- Tension (dECO Screens only)

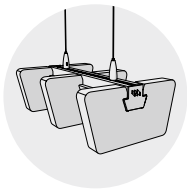

Snap Technology

The exclusive snap blade technology allows for quick and simple installation with the confidence of an instant secure fit.

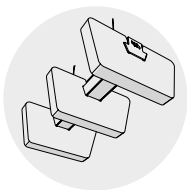

Spacing Versatility

Providing a conceal bespoke finish, the aluminium snap spacer allows for consistent spacing between blades based on your project needs whilst giving you speed for a quick installation.



Assembly Support

Detailed illustrations are available in the Installation guide for each unique hardware execution. CSR Martini also offer technical support if required on all projects.

Integrating Rondo KEY-LOCK® and Verto

At CSR Martini, innovation and ease of installation is always top of mind.

Verto has been engineered to integrate directly into the Rondo KEY-LOCK® system. This exclusive installation feature now allows you to directly clip the Rondo 139 joining clip to the Verto extrusion making this a seamless system integration.

This is an ideal solution if you are looking to incorporate an acoustic blade system within a concealed grid system.



Interior Decorative Acoustic Screen



Applications Vertical hanging decorative acoustic room divider or wall features

Designs dECO Screens Leaf, dECO Screens Lines, dECO Screens Dots, dECO Screens Breeze, dECO Screens Fracture.

Thickness 27mm
Tolerance: +/- 2mm

Height Available in 2400mm or 2700mm

Fire resistance Complies with AS 5637.1 and is tested to AS/ ISO 9705 and achieves Group 1 SMOGRA less than 100 m²/s² x 1000

Acoustic performance Tested to AS/ISO 354 and dECO Screens substrate achieves NRC 0.65 direct fix

Warranty 15 year product warranty

Finish



Installation

dECO Screens are installed on the Verto™ system that can be direct fixed, suspended from soffit or ceiling grid, free hanging or under tension. For more details, refer to dECO Screens datasheet and Installation Guide.



Leaf

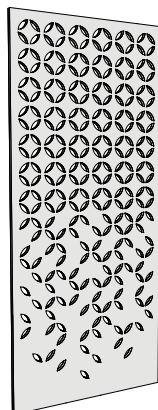

Breeze

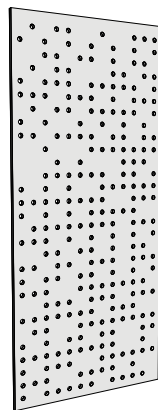

Dots

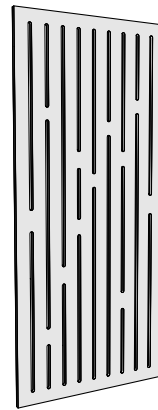

Lines

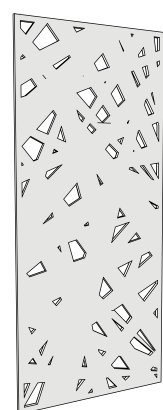

Fracture

Decorative Suspended Acoustic Clouds

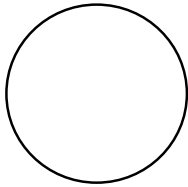

Circle

1200mm, 800mm,
600mm diameter

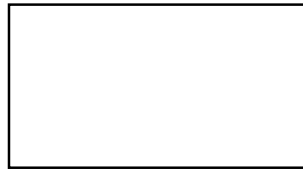

Rectangle

2400 x 1200 x 25mm

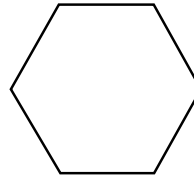

Hexagon

1200 x 1200 x 25mm

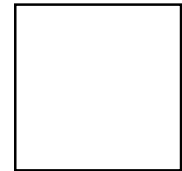

Square

1200 x 1200 x 25mm

Application For interior ceiling applications

Design dECO Clouds Circle 1200mm, dECO Clouds Circle 800mm, dECO Clouds Circle 600mm, dECO Clouds Rectangle, dECO Clouds Square, dECO Clouds Hexagon

Thickness 25 mm
Tolerance: +/- 2mm

Fire resistance Complies with AS 5637.1 and is tested to AS/ ISO 9705 and achieves Group 1 SMOGRA less than 100 m²/s² x 1000

Acoustic performance Tested to AS/ISO 354 and achieves NRC 0.65 direct fix. Refer to dECO Clouds datasheet for Effective Absorptive Area (metric Sabine) results

Warranty 15 year product warranty

Finish



Installation

dECO Clouds can be suspended from soffit or ceiling grids using dECO Clouds Suspension Kit. Refer to dECO Clouds datasheet for number of required suspension kits per design



Decorative Acoustic Drop-In Ceiling Tiles For Grids

Application Decorative acoustic Interior drop-in ceiling tiles for standard exposed 24mm ceiling grid systems

Size 1195mm x 595mm x 25mm
595mm x 595mm x 25mm

Piece /box 1195mm length: 4 tiles
595mm length: 8 tiles

Edge type

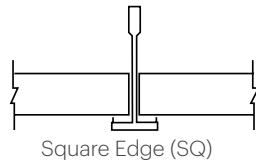

Light reflectance Snow achieves 91 as tested to ASTM E1477-98a

Fire resistance Complies with AS 5637.1 and is tested to AS/ ISO 9705 and achieves Group 1 SMOGRA less than 100 m²/s² x 1000

Acoustic performance Tested to AS/ISO 354 and achieves NRC 0.90 with 400mm plenum

Warranty 15 year product warranty

Finish





3D Decorative Acoustic Wall Tiles

Application	Decorative acoustic three-dimensional wall feature tiles suitable for flat and even surfaces such as Gyprock®
Size	dECO 3D Tiles Abstract, Incline and Shatter 300mm x 346mm x 70mm dECO 3D Tiles Geo and Rubix 300mm x 346mm x 40mm
Tiles /box	8 tiles with acoustic infills. MOQ 3 boxes
Fire resistance	Complies with AS 5637.1 and is tested to AS/ ISO 9705 and achieves Group 1 SMOGRA less than 100 m ² /s ² x 1000
Acoustic performance	Tested to AS/ISO 354 with acoustic infill and achieves Abstract: NRC 0.95 Geo: NRC 0.95 Incline: NRC 0.95 Rubix: NRC 0.8 Shatter: NRC 1.00
Warranty	15 year product warranty
Installation	dECO 3D Tiles are friction-fit mounted on acoustic infill which is attached to the wall with pressure-sensitive adhesive backing. Spacing jig included in tile pack
Finish	



Abstract



Geo



Incline

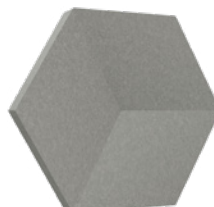

Rubix

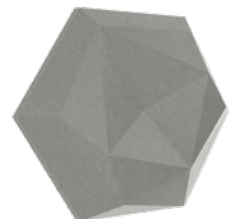

Shatter



Versatile, Self-Adhesive Acoustic Wall Tiles

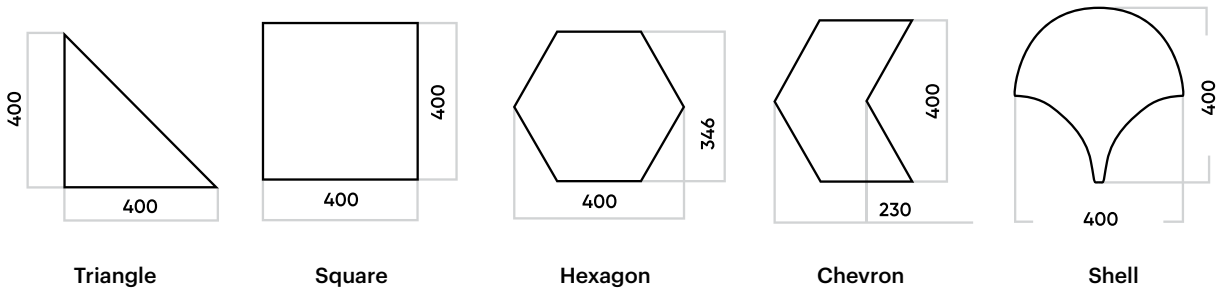

Application	Interior use only, adhered to a flat surface such as Gyprock®
Thickness	13.5mm Tolerance: +/- 2mm
Fire resistance	Tested to AS/NZS 1530.3 and achieves Ignitability Index 8 Spread of Flame Index 0 Heat Evolved Index 3 Smoke Developed Index 7
Acoustic performance	Tested to AS/ISO 354 and achieves NRC 0.50 direct fix
Warranty	15 year product warranty
Installation	With self-adhesive backing, dECO Stick It are easy to install onto a wall
Finish	





High Density and Durable Acoustic Board

Application	Interior wall or ceiling finish and substrate for fabric wrapping
Thickness	24 mm Tolerance: +/- 2mm
Panel size	2410mm x 1210mm Tolerance: length +/- 10mm width +/- 5mm
Fire resistance	Complies with AS 5637.1 and is tested to AS/ ISO 9705 and achieves Group 1 SMOGRA less than 100 m ² /s ² x 1000
Acoustic performance	Tested to AS/ISO 354 and achieves NRC 0.65 direct fix
Warranty	15 year product warranty
Colours	Black and White



High Performance and Durable Acoustic board

Application	Acoustic cover-grade substrate for interior walls and ceilings
Thickness	7mm, 12mm, 25mm, 50mm Tolerance: +/- 2mm
Panel size	2420mm x 1210mm, 2720mm x 1210mm Tolerance: length +/- 10mm width +/- 5mm
Fire resistance	Complies with AS 5637.1 and is tested to AS/ ISO 9705 and achieves Group 1 SMOGRA less than 100 m ² /s ² x 1000
Acoustic performance	Tested to AS/ISO 354 and achieves: 7mm NRC 0.30 direct fix 15mm NRC 0.50 direct fix 25mm NRC 0.85 direct fix 50mm NRC 1.00 direct fix
Warranty	15 year product warranty
Colours	Black and White

Board surface variations may be present. If decorative finish is required, please use dECO Quiet Panel.

Martini High Performance

In some applications, acoustic performance governs over aesthetics. CSR Martini has a range of speciality high performance acoustic boards to meet these demanding acoustical challenges.

dECO Deluxe and dECO Quiet Board are acoustic boards that can be used in exposed and semi-exposed applications where a decorative finish isn't required.



Martini Soffit

High performance under slab soffit acoustic insulation

Application	Martini Soffit is ideal for use as a slab soffit liner in commercial buildings, sports halls, cinemas, studios and retail spaces.
Thickness	50mm and 75mm
Panel size	2400mm x 1200mm
Fire resistance	Complies with AS 5637.1 and is tested to AS/ ISO 9705 and achieves Group 1 SMOGRA less than 100 m ² /s ² x 1000
Acoustic performance	Tested to AS/ISO 354 achieves NRC of: XHD 50/XXHD 50 - 0.9. XHD 75 - 1.00
Warranty	15 year product warranty
Colours	Black, white and grey



Martini Absorb

High performance sound absorptive insulation

Application	Martini Absorb is ideal for use behind perforated panelling and behind ceilings in sports halls, cinemas, studios, industrial enclosures, HVAC ducts, silencers or plant rooms. Martini Absorb can also be laid above suspended ceilings. Absorb is not suitable for fully exposed applications or where a decorative finish is required.
Thickness	Sheets and rolls: 25mm, 50mm, 75mm & 100mm
Panel size	Sheets: 2400mm x 1200mm Rolls: Standard widths are 610mm and 1200mm (Available in a range of lengths)
Fire resistance	Complies with AS 5637.1 and is tested to AS/ ISO 9705 and achieves Group 1 SMOGRA less than 100 m ² /s ² x 1000
Acoustic performance	Tested to AS/ISO 354 - Refer to QR code for NRC values
Warranty	15 year product warranty
Colours	Black and White

Martini Flank Guard

Easy to install noise barrier for commercial ceiling voids

Application	Martini Flank Guard is designed to fill the void above partition walls to control flanking noise between adjoining spaces in commercial and multi-residential buildings.
Length	1200mm
Width	600mm
Pack Size	Batts /pack 8
Fire Resistance	Tested to AS/NZS 1530.3 and achieves Ignitability Index 0 Spread of Flame Index 0 Heat Evolved Index 0 Smoke Developed Index 1
Acoustic Performance	Tested to ASTM E2611-17 and can achieve a sound transmission reduction of up to 9-16 decibels across a range of frequencies.
Warranty	15 year product warranty
Colour	White

NOTE: Density compressed as a kg/m³ is a calculation of Product Weight (gsm) divided by nominal thickness. Martini Flank Guard has a non compressed a of 100mm and a nominal net weight of 1,000gsm. Standard product density (un-compressed) is 10kg/m³.



Rondo ceiling systems are highly innovative and of superior quality, with both concealed grid or exposed grid options, there are solutions available to meet acoustic, fire-rated, wind loading and seismic design requirements.

Rondo Building Services is a market-leading manufacturer of quality, lightweight rolledformed steel wall and ceiling framing products, and provider of compliant design solutions for the construction industry.

Rondo steel wall framing systems provide durable, practical, and lightweight structures for internal plasterboard walls to create attractive spaces within buildings, or external wall systems to provide direct support of the exterior cladding and interior linings. Rondo's high-quality wall and ceiling systems and products are complemented by Rondo's expert technical design support. Rondo Design Engineers focus on providing wall and ceiling design solutions that are customised individually for each project, ensuring project compliance.

Sustainability

Rondo's sustainability vision is to promote safety and sustainability across all levels of operations by educating and consulting staff, contractors, and the supply chain on safe work practices and environmental responsibilities.

Rondo regularly review processes to minimise energy consumption and waste to landfill, while continually exploring technology advancements to reduce annual energy consumption and landfill waste. Rondo is committed to achieving and maintaining a high standard of environmental care across all operations.

[CLICK HERE TO LEARN MORE](#)



The Rondo DUO® Exposed Ceiling Grid System

The Rondo DUO® Exposed Ceiling Grid System is a 24mm exposed ceiling grid system, suitable for a variety of commercial building applications. The Rondo DUO® Exposed Ceiling Grid System consists of Main and Cross-tees and a wide range of system accessories.

Product Properties

- Available in 24mm
- White (RAL 9003)*
- Provides a 30 Year Warranty when used in conjunction with OWA Ceiling Tiles
- Seismic Designs available

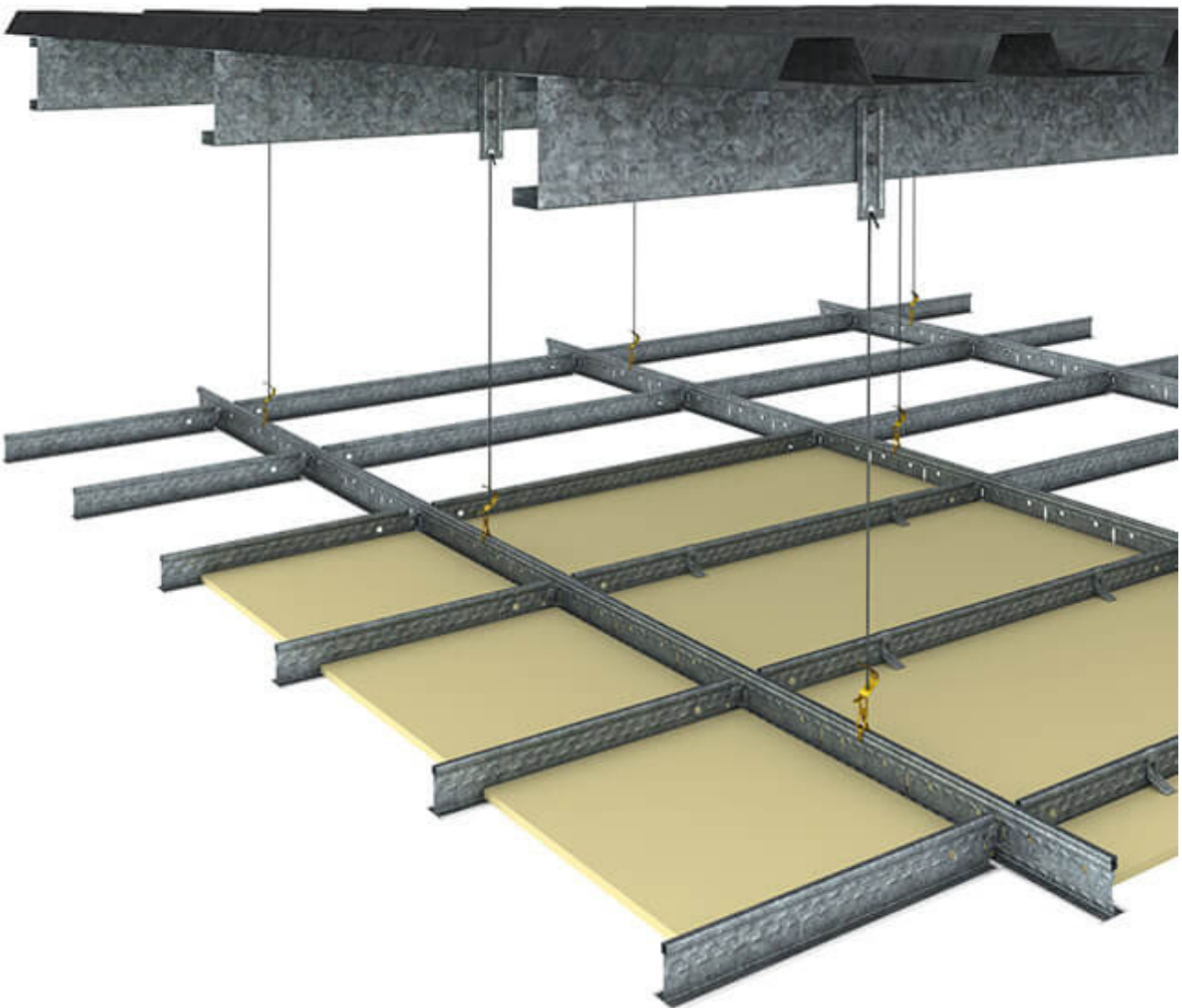

* This item is made to order, therefore minimum order quantities and/or lead times may apply. Please contact the Himmel team for further information.

Primary Sections

ORDER CODE	PRODUCT DESCRIPTION	SIZE	Each/carton
10448	DUO 1 Main Tee	24 (face) x 38 (h) x 3600mm (l)	24
10449	DUO 2 Cross Tee	34 (h) x 24 (face) x 1200mm (l)	68
10450	DUO 2 Cross Tee	34 (h) x 24 (face) x 600mm (l)	68



10448

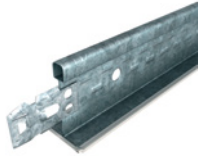

10449

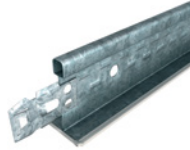

10450



13323

Splines

ORDER CODE	PRODUCT DESCRIPTION	SIZE	Each/carton
13323	371 22mm T Spline	1187mm	10

Wall Angles & Bulkhead Trim

ORDER CODE	PRODUCT DESCRIPTION	SIZE	Each/carton
10451	DUO 5 Rolled Edge Wall Angle: Steel	25 x 19mm	24
10452	DUO 6 Shadowline Wall Angle: Steel	19 x 9 x 9 x 15mm	24
30190	DUO 7 Shadowline Wall Angle: Aluminium	19 x 9 x 9 x 15mm	30
88220	DUO 8 Aluminium Wall Angle	32 x 19mm	24
10433	321 Aluminium Bulkhead Trim	3600mm	12



10451



10452



88220

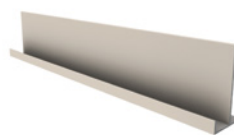

10433

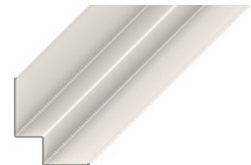

30190



10422



10447



10421

Joiners

ORDER CODE	PRODUCT DESCRIPTION	SIZE	Each/carton
10421	Joiner: Duo 5	-	250
10422	Joiner: Duo 6 and 7	-	250
10447	DUO 5 Bulkhead Clip	-	250

* This item is made to order, therefore minimum order quantities and/or lead times may apply. Please contact the Himmel team for further information.

Rondo DONN® Exposed Grid Ceiling System

The Rondo DONN® Exposed Grid Ceiling System provides the framework for a variety of lay-in tiles including; acoustic, perforated plasterboard, PVC laminated, and metal. The Rondo DONN® Exposed Grid Ceiling System includes the popular 24mm face grid, also offering a more slimline 15mm face grid option to give designers an alternative grid appearance and installers a system they already know. The well-known DONN® Quick Release Clips (QRC) are located on the ends of Rondo DONN® Cross Tees to enable fast and easy installations without the need for mechanical tools or fixing.

Product Properties

Available in a 24mm face grid – white & black

15mm face grid – white only (MTO)

Quick Release Clips (QRC)- high tensile, allows for quick and easy installation.

24mm available in White and Black

Seismic Designs available

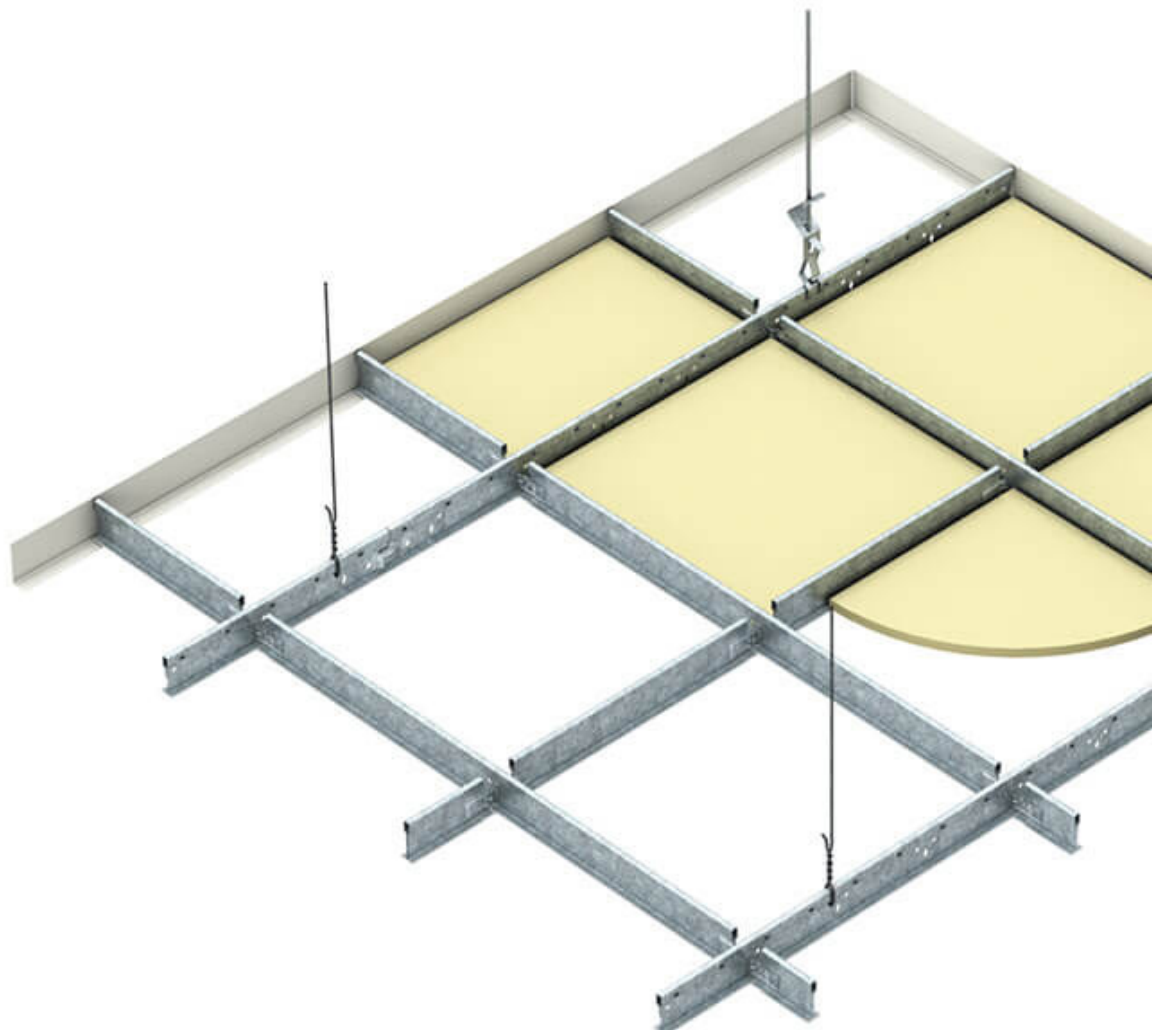

Primary Sections

ORDER CODE	PRODUCT DESCRIPTION	SIZE	Each/carton
197801	DONN Main Tee	24 (face) x 38 (h) x 3600mm (l)	24
197811	DONN Cross Tee	32 (h) x 24 (face) x 1200mm (l)	68
197812	DONN Cross Tee	25 (h) x 24 (face) x 600mm (l)	68



197801



197811



197812

ORDER CODE	PRODUCT DESCRIPTION	SIZE	Each/carton
89224	DONN Main Tee BLK	24 (face) x 38 (h) x 3600mm (l)	24
89225	DONN Cross Tee BLK	32 (h) x 24 (face) x 1200mm (l)	68
114301	DONN Cross Tee BLK	25 (h) x 24 (face) x 600mm (l)	68



89224



89225



114301

Wall Angles

ORDER CODE	PRODUCT DESCRIPTION	SIZE	Each/carton
197813	DONN Wall Angle: Steel	22 x 19mm	24
197814	DONN Wall Angle: Steel	40 x 19mm	24
461612	DONN Wall Angle: Aluminium	27 x 10 x 10mm	30
89226	DONN Wall Angle BLK	20 x 19mm	30
62688	Seismic Clip Grd to Wall Angle		30

Suspension Clips & Brackets

ORDER CODE	PRODUCT DESCRIPTION	SIZE	Each/carton
10440	700 Spring adjustable clip for 5mm soft galv suspension rod	107mm	400
10441	701 Thread Adjustable Clip for M6 Threaded Rod (with lock nut)	83mm	400
14911	719 Hooked Adjustable Suspension Clip	-	500
10432	247 Suspension Rod Angle Bracket	60mm	400
10410	274 Suspension Rod Bracket	79mm	500
27792	547 Suspension Rod Bracket: Concrete	78mm	250



10440



10441



14911



27792



10432



10410



10442

Direct Fixing Clip

ORDER CODE	PRODUCT DESCRIPTION	SIZE	Each/carton
10442	127mm Direct Fixing Hanger to Timber/Steel	127mm	250



10389



10423

Suspension Rods & Nuts

ORDER CODE	PRODUCT DESCRIPTION	SIZE	Each/carton
10389	121 5mm Soft Galv. Rod: Plain	3600mm	50
10423	826 M6 Nut to Suit Threaded Rod	-	200



10443



10444



12187



14040



10445

Accessories

ORDER CODE	PRODUCT DESCRIPTION	Ea/carton
10443	703 Tile Holddown Clip for 10mm for 16mm tiles	100
14040	704 Partition Mounting Clip: 51-64-76-92-150 Stud Walls	50
10444	705 Stabiliser clip to suit DUO 5 and DUO 8 main/cross tees	100
10445	706 Stabiliser clip to suit DUO 6 and DUO 7 main/cross tees	100
12187	707 Interchange Clip: 127/DUO1	250

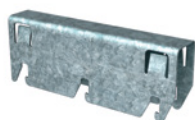

103077

Air Diffuser Clip

ORDER CODE	PRODUCT DESCRIPTION	Each/carton
103077	713 3-Tee Bar: 50mm Centres	100

* This item is made to order, therefore minimum order quantities and/or lead times may apply. Please contact the Himmel team for further information.

The Rondo Xpress[®] Drywall Grid Ceiling System

The Rondo Xpress[®] Drywall Grid Ceiling System is light-weight and simple to install.

The Main Tee and Cross Tee connection uses the same patented QRC clip technology that is known and preferred by installers.

With an ability to be used in acoustic, seismic and fire-rated applications, the Rondo Xpress[®] Drywall Grid Ceiling System offers design flexibility for flush plasterboard ceilings, bulkheads and boxed soffits.

Main Tees

ORDER CODE	PRODUCT DESCRIPTION	SIZE	Each/carton
194969	Main Tee XD1	38 x 38 x 3600mm	12
450389	Main Tee Heavy Gauge XD1H	38 x 38 x 3600mm	12



194969



450389

Cross Tees

ORDER CODE	PRODUCT DESCRIPTION	SIZE	Each/carton
194970	Cross Tee XD2 600	38 x 38 x 600mm	36
195041	Cross Tee XD2 1200	38 x 38 x 1200mm	36
452990	Cross Tee XD2 1250	38 x 38 x 1250mm	36
195043	Cross Tee XD2 1600	38 x 38 x 1600mm	36



194970



195041



452990



195043

Wall Trims

ORDER CODE	PRODUCT DESCRIPTION	SIZE	Each/carton
195044	Wall Angle XD5	40 x 40 x 3600mm	
195045	Perimeter Channel XD6	40 x 38 x 19mm	

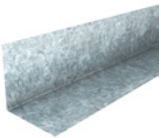

195044

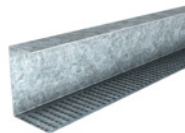

195045

Clips

ORDER CODE	PRODUCT DESCRIPTION	SIZE	Each/carton
453357	Splice Clip XDSC	-	
453348	Transition Clip XD10	-	
450387	3-Way Off-Module Connector XD36	-	
450386	Acoustical Transition Clip XD11	-	



453357



453348



450387



450386

Suspension Clips

ORDER CODE	PRODUCT DESCRIPTION	SIZE	Each/carton
450388	Suspension Clip DXCL	-	
455349	Direct Fix Strap	-	
10432	247 Suspension Rod Angle Bracket	-	
10410	274 Suspension Rod Bracket	-	
27792	547 Suspension Rod Bracket: Concrete	-	



455349



10432



10410



27792

* This item is made to order, therefore minimum order quantities and/or lead times may apply. Please contact the Himmel team for further information.



Fricker Aluminium Ceiling Grid is a premium system that is designed for high end commercial applications. Manufactured in Sydney, the Fricker Aluminium Ceiling Grid range is available in Top Hat, Flush Face and Slimline profiles and can be manufactured in 1200 x 1200mm, 1350 x 1350mm and 1500 x 1500mm module (modules can include 2 – 5 tiles). CSR Himmel can deliver an Aluminium Grid System that is customisable to your project needs. Fricker is available in a diverse range of solutions to suit various commercial developments including offices, education facilities, healthcare facilities, retail and industrial developments. Fricker is proudly Australian Made and Owned.

[CLICK HERE TO LEARN MORE](#)



ALUMINIUM CEILING GRID

Fricker Aluminium Ceiling Grid is a premium system that is designed for high end commercial applications. Manufactured in Sydney, the Fricker Aluminium Ceiling Grid range is available in the Top Hat, Flush Face and Slimline profiles. It can be manufactured in 1200 x 1200mm, 1350 x 1350mm and 1500 x 1500mm module (modules can include 2 – 5 tiles). Custom sizes are available upon request.

Fricker Top Hat Aluminium Profile

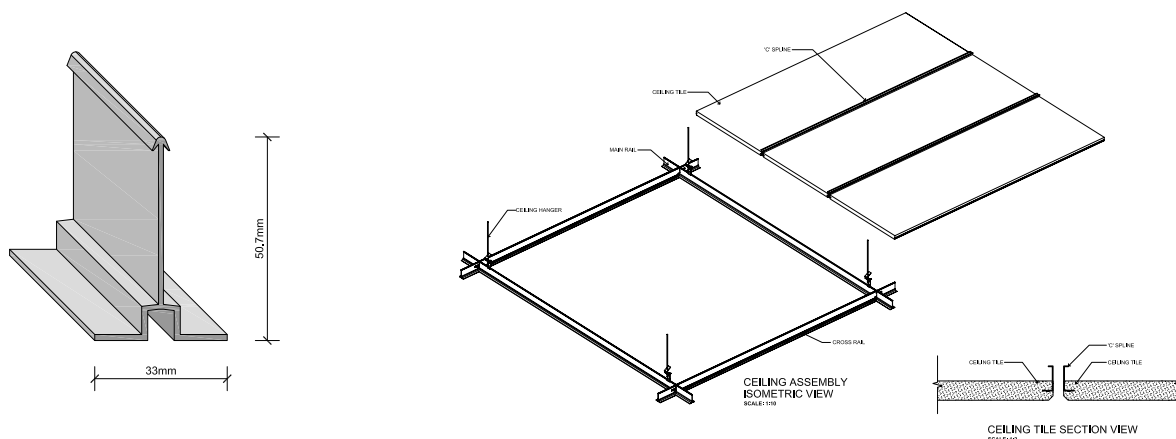

Fricker Flush Face Aluminium Profile

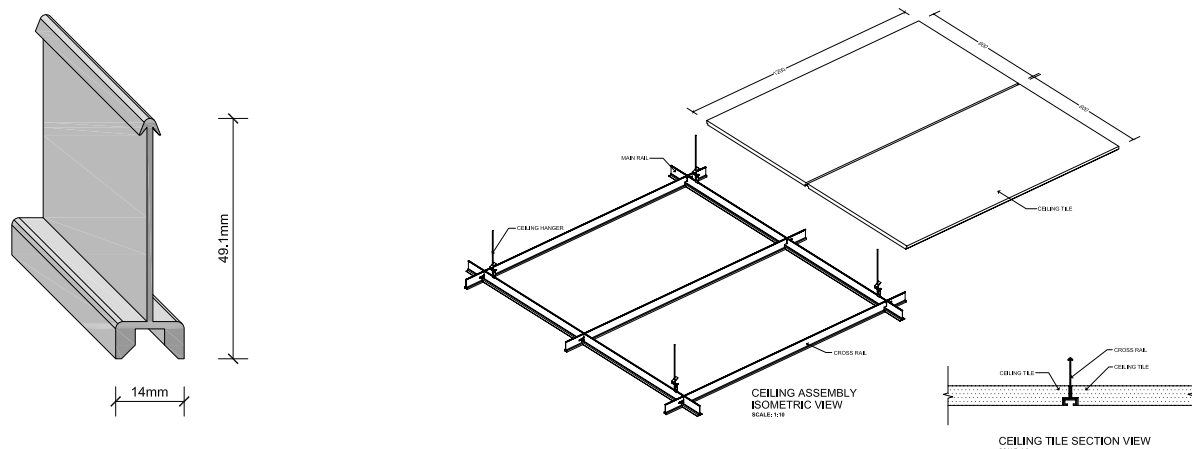

Fricker Slimline

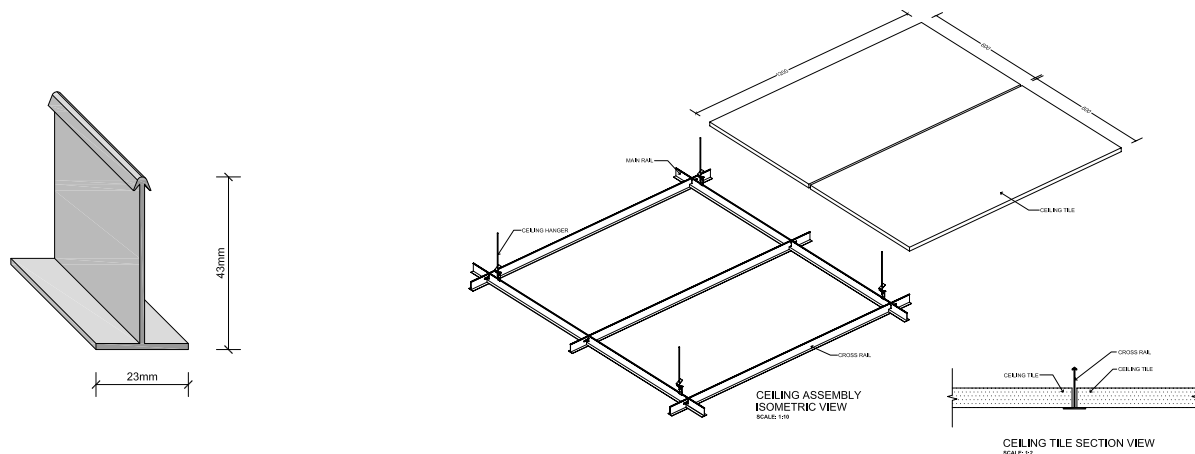

* This item is made to order, therefore minimum order quantities and/or lead times may apply. Please contact the Himmel team for further information.

Fricker Top Hat Aluminium

ORDER CODE	PRODUCT DESCRIPTION	SIZE	Each/carton
90729	Main Runner - Mitred	33 (face) x 50.7 (h) x 3600mm (l)	24
91307	Cross Runner - Mitred	33 (face) x 50.7 (h) x 1200mm (l)	24
90721	Main Runner - Mitred	33 (face) x 50.7 (h) x 4050mm (l)	24
91301	Cross Runner - Mitred	33 (face) x 50.7 (h) x 1350mm (l)	24
90741	Main Runner - Mitred	33 (face) x 50.7 (h) x 4500mm (l)	24
90522	Cross Runner - Mitred	33 (face) x 50.7 (h) x 1500mm (l)	24

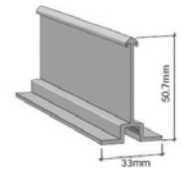

TOP HAT

Fricker Flush Face Aluminium

ORDER CODE	PRODUCT DESCRIPTION	SIZE	Each/carton
90107	Main Runner	23 (face) x 43 (h) x 3600mm (l)	40
90340	Cross Runner	23 (face) x 43 (h) x 1200mm (l)	40
90343	Cross Runner	23 (face) x 43 (h) x 600mm (l)	40

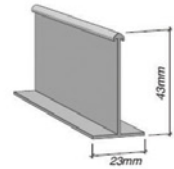

FLUSH FACE

Fricker Inverted U/Slimline Aluminium

ORDER CODE	PRODUCT DESCRIPTION	SIZE	Each/carton
90617	Main Runner	14 (face) x 49 (h) x 3600mm (l)	40
90500	Cross Runner	14 (face) x 49 (h) x 1200mm (l)	40
90501	Cross Runner	14 (face) x 43 (h) x 600mm (l)	40

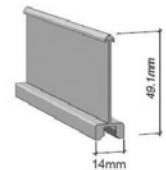

SLIMLINE

Fricker Inverted U/Slimline Aluminium - 1350 x 450

ORDER CODE	PRODUCT DESCRIPTION	SIZE	Each/carton
90616	Main Runner	14 (face) x 49 (h) x 4050mm (l)	40
90499	Cross Runner	1350 (l) x 49 (h) x 14mm (face)	40

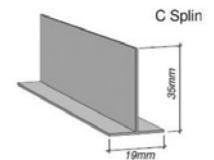

T SPLINE

Fricker Aluminium Wall Angle

ORDER CODE	PRODUCT DESCRIPTION	SIZE	Each/carton
93320	Wall Angle Shadowline	3660 x 10 x 10mm	30
89948	Wall Angle 20mm	3250 x 25 x 20mm	10

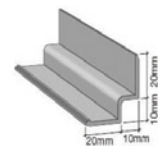

WALL ANGLE SHADOWLINE

Fricker C Splines

ORDER CODE	PRODUCT DESCRIPTION	SIZE	Each/carton
128241	C Spline	1185 x 25 x 10mm	EA
133327	C Spline	1333 x 11 x 23mm	EA
89953	C Spline	1485 x 35 x 10mm	20

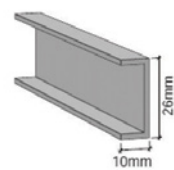

C SPLINE

Fricker Clips & Accessories

ORDER CODE	PRODUCT DESCRIPTION	Ea/carton	ORDER CODE	PRODUCT DESCRIPTION	Ea/carton
90614	Main Runner Joiner Clip 39.5mm	100	89941	Bulkhead Trim 3660 x 27 x 50mm White	EA
90283	Suspension Clip	100			

* This item is made to order, therefore minimum order quantities and/or lead times may apply. Please contact the Himmel team for further information.

Pelmet

ORDER CODE	PRODUCT DESCRIPTION	SIZE	Each/carton
121607	Fricker Aluminium Pelmet	3600mm	1
MADE TO ORDER	Aluminium Blind Box	Custom	1

Perimeter Trims

ORDER CODE	PRODUCT DESCRIPTION	SIZE	Each/carton
313816	Screwfix Main Runner MRFF23	3660 x 43 x 23mm	1
96499	Screwfix Shadowline WASLAF	3610 x 10 x 10mm	1
89941	Bulkhead Trim Plasterboard MRFF23	3660 x 50 x 27mm	1

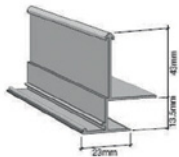

SCREWFIX MAIN
RUNNER EDGE DIAGRAM

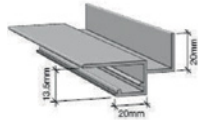

SCREWFIX SHADOWLINE & WALL
ANGLE EDGE DIAGRAM

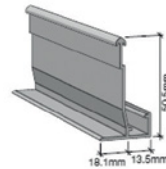

BULKHEAD TRIM DIAGRAM

Made To Order

PRODUCT DESCRIPTION
Column Trim
Diffuser Cradle
Curved Grid
Customised size aluminium suspension systems

TILE EDGE MATRIX

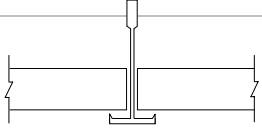
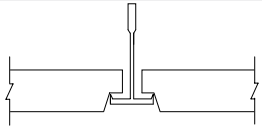
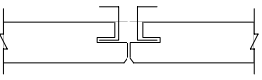
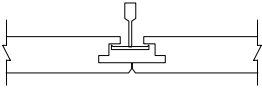
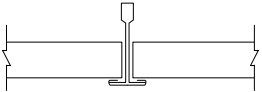
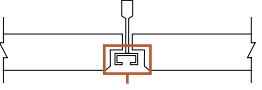
EDGE DETAIL	STEEL GRID			ALUMINIUM GRID		
	24MM RONDO DUO STEEL GRID	24MM RONDO DONN STEEL GRID	15MM RONDO DON STEEL GRID	FRICKER 14MM SLIMLINE GRID	FRICKER 23MM FLUSH FACE GRID	FRICKER 33MM TOP HAT GRID
 SQUARE EDGE	■	■			■	■
 SLT EDGE	■	■			■	
 SBK EDGE						■
 CONCEALED EDGE	■	■			■	■
 T15 EDGE			■			
 EDGE DETAIL IS NON PAINTED 15B EDGE				■		

Designed by Himmel Interior Systems in Australia, our aluminium partitioning suite incorporates a host of proven innovative concepts to assist both design and installation.

Aluminium is a proven construction material for buildings, vehicles, appliances, and products, both as a framing and cladding material. In the building industry, it is by far the most common material used for window and door joinery, curtain walls and shop fronts. Its selection is based on many criteria – one being its ease of fabrication to provide visual appeal and easy maintenance.

Today's design trends along with the new world we live in brings the need to evolve existing larger open plan spaces efficiently into smaller offices allowing individuals or teams to have their own space to feel safe in. Our innovative range of systems support, inspire and enable people to collaborate, share knowledge, learn together, build, and produce innovation and success.

Himmel Interior Systems series of aluminium partitioning systems incorporates a number of design elements that are largely interchangeable.

Himmel Aluminium partitioning suite includes:

- Partions
- Skirting and Flat Bar
- Doors & Sliders

[CLICK HERE TO LEARN MORE](#)



Himmel Aluminium Partition Suites

Himmel Aluminium partitioning suites incorporate a host of proven innovative concepts to assist both design and installation.

Aluminium is a proven construction material for buildings, vehicles, appliances, and products, both as a framing and cladding material. In the building industry, it is by far the most common material used for window and door joinery, curtain walls and shop fronts. Its selection is based on many criteria – one being its ease of fabrication to provide visual appeal and easy maintenance.



Available in:



Clear Anodised

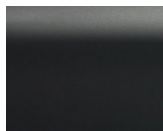

Dulux
Matte Black

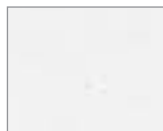

Other Powdercoat
options available

Partition A Series 104

A Series 104 provides a central line glazing with numerous configurations and design options offering a complete partition system for plasterboard and glazing.

A Series 104 has the following features:

- 25mm / 35mm / 50mm reveal options
- Pocket depth inside 18mm
- Available length - 2800mm / 3600mm
- Centre glazing option only
- Standard wall size based on 64mm steel stud with one layer of 13mm Gyprock plaster board on each side
- Can accommodate glass thicknesses between 6mm and 13mm
- Shadowline details optional
- Can be used with CS45 and DS45 series



Available in:



Clear Anodised

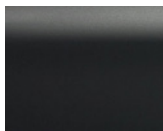

Dulux
Matte Black

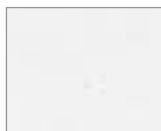

Other Powdercoat
options available

Partition DS Series 45

DS Series 45 are a combination of doors and sliders designed to fit with Himmel Aluminium Systems, with the following features:

- Available in 45mm thick doors only
- Styles and rails sizes 60mm, 66mm, 83mm and 114mm
- Can accommodate glass thickness of 12.76mm thick laminated glass
- Door kits available in 62mm & 114mm Stile



Available in:



Clear Anodised

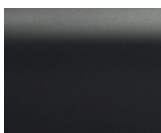

Dulux
Matte Black

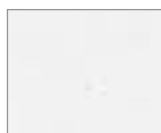

Other Powdercoat
options available

Partition A Series 132

A Series 132 provides a central line glazing with numerous configurations and design options, offering a complete partition system for Gyprock plasterboard and glazing.

A Series 132 has the following features:

- 25mm / 35mm / 50mm reveal options
- Pocket depth inside 18mm
- Standard wall size based around 92mm steel stud with one layer of 13mm Gyprock plaster board on each side
- Can accommodate glass thickness between 6mm - 12.76mm
- Shadow line details optional
- Can be used with CS45 and DS45 series



Available in:

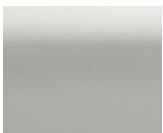

Clear Anodised

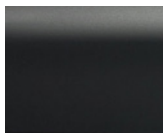

Dulux
Matte Black

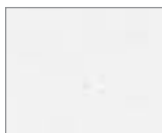

Other Powdercoat
options available

Partition E Series 104

E Series 104 provides choice of offset or double glazing with numerous configurations and design options in conjunction with A series, offering a complete partition system for plasterboard and glazing.

E Series 104 has the following features:

- 25mm / 35mm / 50mm reveal options
- Available length - 2800mm/3600mm
- Offset and Double glazing options only
- Standard wall size based around 64mm steel stud with one layer of 13mm Gyprock plaster board on each side
- Can accommodate glass thickness between 6mm – 13mm
- Can be used with AS104, CS45 and DS45 series



Available in:



Clear Anodised



Dulux
Matte Black

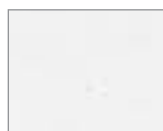

Other Powdercoat
options available

Partition C Series 45

C Series 45 is used as an entry level system when the budget is a factor, it can be designed into the A Series for a slimmer look.

C Series 45 has the following features:

- Standard glazing profile of 45mm wide x 25mm high
- Can be used with the AS104/AS132 suite by using the Head/sill track
- Can accommodate glass thicknesses between 6mm and 12.76mm
- Can accommodate door thicknesses between 32mm, 35mm and 45mm
- Door frame kits available



Available in:



Clear Anodised

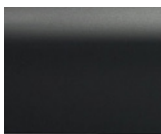

Dulux
Matte Black

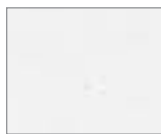

Other Powdercoat
options available

Partition E Series 132

E Series 132 provides choice of offset or double glazing with numerous configurations and design options in conjunction with our A series, offering a complete partition system for plasterboard and glazing.

E Series 132 has the following features:

- 25mm / 35mm / 50mm reveal options
- Available length - 2800mm/3600mm
- Offset and Double glazing options only
- Standard wall size based around 64mm steel stud with one layer of 13mm Gyprock plaster board on each side
- Can accommodate glass thickness between 6mm - 13mm
- Can be used with AS132, CS45 and DS45 series

Himmel Aluminium SOHO Series

The Himmel Aluminium SOHO Series provides designers with the option to retro-fit windows and doors, achieving a Crittall style window, reminiscent of the SOHO Style of New York. Available in two different profiles; flat and raised, the SOHO Series is easy to and install and is in stock and ready for your next project. The SOHO Series is designed to provide an artistic feel to the suits and are not necessary to strengthen the structure of the partitioning in situ.

The lightweight, cost-effective alternative to traditional glazing is easier to fabricate and install, while refusing to compromise on its stunning industrial-inspired aesthetics.

Being extremely versatile, the Himmel Aluminium SOHO Series is capable of combining with Himmel Partition suites to deliver unique solutions for the office that's on-trend. The lightweight aluminium is attached to the glazing with industrial strength adhesive and can be positioned onto the glazing panel in a variety of ways, limited by the imagination.



The Soho Series consist of two 35mm options; A-Frame Bars and Flat Bars, both of which are intended to complement the visual appeal of Aluminium Himmel Partition Suites and Doors. Soho is designed to provide an artistic feel to the suites and are not necessary to strengthen the structure of the partitioning insitu.

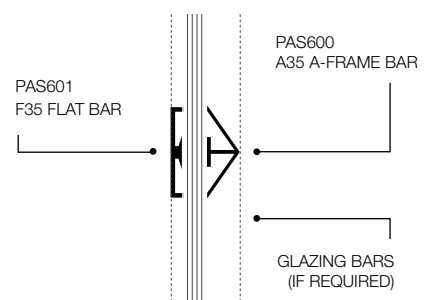

* This item is made to order, therefore minimum order quantities and/or lead times may apply. Please contact the Himmel team for further information.

FLATBAR AND SKIRTING



Himmel offers a premium range of flat bar and screw on skirting in multiple widths, colours and length for all your commercial finishing needs.

Skirting



DESCRIPTION (A)	LENGTH	CLEAR ANODISE	P/COATED BLACK	P/COATED WHITE
SKIRTING - 50mm	2800mm	181530		
SKIRTING - 100mm	2800mm	103282	108773	181550
SKIRTING - 100mm	3600mm	103298	160218	181568
SKIRTING - 125mm	2800mm	166220		
SKIRTING - 150mm	2800mm	103283	160219	
SKIRTING - 150mm	3600mm	103299	160220	

Flat Bar

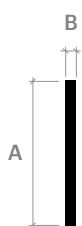

DESCRIPTION (A X B)	LENGTH	CLEAR ANODISE	P/COATED BLACK	P/COATED WHITE
FLAT BAR - 25mm x 1.6mm	2800mm	103262	160237	154965
FLAT BAR - 25mm x 1.6mm	4000mm	157528		
FLAT BAR - 25mm x 3mm	2800mm	181837	181839	181840
FLAT BAR - 25mm x 3mm	4000mm	181856		
FLAT BAR - 50mm x 1.6mm	2800mm		182846	182847
FLAT BAR - 50mm x 1.6mm	4000mm	182848	182850	182851
FLAT BAR - 50mm x 3mm	2800mm	169483	181876	179006
FLAT BAR - 50mm x 3mm	4000mm	159092	181915	181916
FLAT BAR - 100mm x 1.6mm	2800mm	155058	170413	179646
FLAT BAR - 100mm x 1.6mm	3600mm	170412	163907	179185
FLAT BAR - 100mm x 3mm	2800mm	181946	181948	181949
FLAT BAR - 100mm x 3mm	4000mm	159054	181973	181974
FLAT BAR - 150mm x 1.6mm	2800mm	181928	181930	181931
FLAT BAR - 150mm x 1.6mm	3600mm	170414	181952	
FLAT BAR - 150mm x 3mm	3600mm	181989		

Skirting Screws

DESCRIPTION	COLOUR	CODE
126GPZP 12mm x 6G P/H SKIRTING SCREWS (100pk)	Zinc Plated	155049
346GPZP 19MM x 6G P/H SKIRTING SCREWS (100pk)	Zinc Plated	155047
126GPBOX 12MM X 6G P/H BOX (1000pk)	Zinc Plated	183123
346GPBOX 19MM X 6G P/H BOX (1000pk)	Zinc Plated	183138

Universal Skirting Corners

DESCRIPTION	COLOUR	CODE
100MM CORNER	Black	456991
100MM CORNER	Grey	455381
150MM CORNER	Black	456992
150MM CORNER	Grey	455382

Moulded Skirting Cover Strip

DESCRIPTION	COLOUR	CODE
MOULD COVER STRIP 50M	Black	155028
MOULD COVER STRIP 50M	Grey	155029

Flat Skirting Cover Strip

DESCRIPTION	COLOUR	CODE
FLAT COVER STRIP 50M	Black	103248
FLAT COVER STRIP 50M	Grey	103249
FLAT COVER STRIP 200M	Black	155032
FLAT COVER STRIP 200M	Grey	155033

Skirting Adhesive

DESCRIPTION	COLOUR	CODE
SEALANT TOOLBOX MS POLYMER	Black	183195
SEALANT TOOLBOX MS POLYMER	Grey	99935
SEALANT TOOLBOX MS POLYMER	White	99936
SEALANT TOOLBOX MS POLYMER	Clear	183197

Universal Skirting Joiner

DESCRIPTION	COLOUR	CODE
JOINER	Black	455383

HIMMEL™

1300 374 253 | www.himmel.com.au

The Himmel team can assist you with any project or enquiry.
Contact us on 1300 374 253 or email us at HimmelCustomerService@csr.com.au

Himmel™ Locations

NSW

26 Steel St,
Blacktown
NSW 2148
1300 374 253

QLD

Gate 3, Shed 20
221 Hedley Ave,
Hendra QLD 4011
07 3212 6467

VIC

131 Calarco Dr,
Derrimut
VIC 3030
(03) 9217 8700

SA

Lot 100 Sharp
Court,
Mawson Lakes
SA 5095
08 8344 0666

WA

6 Ledger Rd,
Balcatta
WA 6021
08 6241 6800

CSR

MAR2023